

## SkyLine PremiumS Electric Combi Oven 6GN 1/1, left hinged door

ITEM # \_\_\_\_\_

MODEL # \_\_\_\_\_

NAME # \_\_\_\_\_

SIS # \_\_\_\_\_

AIA # \_\_\_\_\_

**217726 (ECO6IT2AL)**

SkyLine PremiumS Combi Boiler Oven with touch screen control, 6x1/1GN, electric, 3 cooking modes (automatic, recipe program, manual), automatic cleaning, left-hinged door

### Short Form Specification

#### Item No.

- Combi oven with high resolution full touch screen interface, multilanguage
- Built-in steam generator with real humidity control based upon Lambda Sensor
  - OptiFlow air distribution system to achieve maximum performance with 7 fan speed levels
  - SkyClean: Automatic and built-in self cleaning system with integrated descale of the steam generator. 5 automatic cycles (soft, medium, strong, extra strong, rinse-only) and green functions to save energy, water, detergent and rinse aid
  - Cooking modes: Automatic (9 food families with 100+ different pre-installed variants); Programs (a maximum of 1000 recipes can be stored and organized in 16 different categories); Manual (steam, combi and convection cycles); Specialistic Cycles (regeneration, Low Temperature Cooking, proving, EcoDelta, Sous-Vide, Static-Combi, Pasteurization of pasta, dehydration, Food Safe Control and Advanced Food Safe Control)
  - Special functions: MultiTimer cooking, Plan-n-Save to cut running costs, Make-it-Mine to customize interface, SkyHub to customize homepage, agenda MyPlanner, SkyDuo connection to SkyLine ChillerS, automatic backup mode to avoid downtime
  - USB port to download HACCP data, programs and settings. Connectivity ready
  - 6-point multi sensor core temperature probe
  - Double glass door with LED lights
  - Stainless steel construction throughout
  - Supplied with n.1 tray rack 1/1 GN, 67 mm pitch.

### Main Features

- Built-in steam generator for highly precise humidity and temperature control according to the chosen settings.
- Real humidity control based upon Lambda Sensor to automatically recognize quantity and size of food for consistent quality results.
- Dry, hot convection cycle (25 °C - 300 °C): ideal for low humidity cooking.
- Combination cycle (25 °C - 300 °C): combining convected heat and steam to obtain humidity controlled cooking environment, accelerating the cooking process and reducing weight loss.
- Low temperature Steam cycle (25 °C - 99 °C): ideal for sous-vide, re-thermalization and delicate cooking.  
 Steam cycle (100 °C): seafood and vegetables.  
 High temperature steam (25 °C - 130 °C).
- Automatic mode including 9 food families (meat, poultry, fish, vegetables, pasta/rice, eggs, savory and sweet bakery, bread, dessert) with 100+ different pre-installed variants. Through Automatic Sensing Phase the oven optimizes the cooking process according to size, quantity and type of food loaded to achieve the selected cooking result. Real time overview of the cooking parameters. Possibility to personalize and save up to 70 variants per family.
- Cycles+:
  - Regeneration (ideal for banqueting on plate or rethermalizing on tray),
  - Low Temperature Cooking (to minimize weight loss and maximize food quality) Patented US7750272B2 and related family,
  - Proving cycle,
  - EcoDelta cooking, cooking with food probe maintaining preset temperature difference between the core of the food and the cooking chamber,
  - Sous-vide cooking,
  - Static Combi (to reproduce traditional cooking from static oven),
  - Pasteurization of pasta,
  - Dehydration cycles (ideal for drying fruits, vegetables, meats, seafood),
  - Food Safe Control (to automatically monitor safety of cooking process in compliance with HACCP hygienic standards) Patented US6818865B2 and related family,
  - Advanced Food Safe Control (to drive the cooking with pasteurization factor).
- Programs mode: a maximum of 1000 recipes can be stored in the oven's memory, to recreate the exact same recipe at any time. The recipes can be group in 16 different categories to better organize the menu. 16-step cooking programs also available.
- MultiTimer function to manage up to 20 different cooking cycles at the same time, improving flexibility and ensuring excellent cooking results. Can be saved up to 200 MultiTimer programs.
- Fan with 7 speed levels from 300 to 1500 RPM and reverse rotation for optimal evenness. Fan stops in less than 5 seconds when door is opened.
- 6-point multi sensor core temperature probe for

APPROVAL: \_\_\_\_\_

maximum precision and food safety.

- Pictures upload for full customization of cooking cycles.
- Automatic fast cool down and pre-heat function.
- Different chemical options available: solid (phosphate-free), liquid (requires optional accessory).
- GreaseOut: predisposed for integrated grease drain and collection for safer operation (dedicated base as optional accessory).
- USB port to download HACCP data, share cooking programs and configurations. USB port also allows to plug-in sous-vide probe (optional accessory).
- Back-up mode with self-diagnosis is automatically activated if a failure occurs to avoid downtime.
- Capacity: 6 GN 1/1 trays.
- OptiFlow air distribution system to achieve maximum performance in chilling/heating evenness and temperature control thanks to a special design of the chamber.

### Construction

- Double thermo-glazed door with open frame construction, for cool outside door panel. Swing hinged easy-release inner glass on door for easy cleaning.
- Hygienic internal chamber with all rounded corners for easy cleaning.
- 304 AISI stainless steel construction throughout.
- Front access to control board for easy service.
- Integrated spray gun with automatic retracting system for fast rinsing.
- IPX 5 spray water protection certification for easy cleaning.
- Supplied with n.1 tray rack 1/1 GN, 67 mm pitch.

### User Interface & Data Management

- High resolution full touch screen interface (translated in more than 30 languages) - color-blind friendly panel.
- Make-it-mine feature to allow full personalization or locking of the user interface.
- SkyHub lets the user group the favorite functions in the homepage for immediate access.
- MyPlanner works as an agenda where the user can plan the daily work and receive personalized alerts for each task.
- With SkyDuo the Oven and the Blast Chiller are connected to each other and communicate in order to guide the user through the cook&chill process optimizing time and efficiency (requires optional accessory).
- Connectivity ready for real time access to connected appliances from remote and HACCP monitoring (requires optional accessory).
- Trainings and guidances supporting materials easily accessible by scanning QR-Code with any mobile device.
- Automatic consumption visualization at the end of the cycle.
- Connectivity ready for real time access to connected appliances from remote and data monitoring (requires optional accessory - contact the Company for more details).

### Sustainability

- Human centered design with 4-star certification for ergonomics and usability.
- Wing-shaped handle with ergonomic design and

hands-free opening with the elbow, making managing trays simpler. Protected by registered design (EM003143551 and related family).

- Reduced power function for customized slow cooking cycles.
- SkyClean: Automatic and built-in self cleaning system with integrated descale of the steam generator. 5 automatic cycles (soft, medium, strong, extra strong, rinse-only) and green functions to save energy, water, detergent and rinse aid. Also programmable with delayed start.
- Plan-n-Save function organizes the cooking sequence of the chosen cycles optimizing the work in the kitchen from a time and energy efficiency point of view.
- Zero Waste provides chefs with useful tips for minimizing food waste. Zero Waste is a library of Automatic recipes that aims to:
  - give a second life to raw food close to expiration date (e.g.: from milk to yogurt)
  - obtain genuine and tasty dishes from overripe fruit/vegetables (usually considered not appropriate for sale)
  - promote the use of typically discarded food items (e.g.: carrot peels).
- Energy Star 2.0 certified product.

### Optional Accessories

- |  |            |                          |
|--|------------|--------------------------|
| • External reverse osmosis filter for single tank Dishwashers with atmosphere boiler and Ovens             | PNC 864388 | <input type="checkbox"/> |
| • Water filter with cartridge and flow meter for high steam usage (combi used mainly in steaming mode)     | PNC 920003 | <input type="checkbox"/> |
| • Water filter with cartridge and flow meter for low steam usage (less than 2 hours of full steam per day) | PNC 920004 | <input type="checkbox"/> |
| • Wheel kit for 6 & 10 GN 1/1 and 2/1 GN oven base (not for the disassembled one)                          | PNC 922003 | <input type="checkbox"/> |
| • Pair of AISI 304 stainless steel grids, GN 1/1   | PNC 922017 | <input type="checkbox"/> |
| • Pair of grids for whole chicken (8 per grid - 1,2kg each), GN 1/1  | PNC 922036 | <input type="checkbox"/> |
| • AISI 304 stainless steel grid, GN 1/1  | PNC 922062 | <input type="checkbox"/> |
| • Grid for whole chicken (4 per grid - 1,2kg each), GN 1/2   | PNC 922086 | <input type="checkbox"/> |
| • External side spray unit (needs to be mounted outside and includes support to be mounted on the oven)    | PNC 922171 | <input type="checkbox"/> |
| • Baking tray for 5 baguettes in perforated aluminum with silicon coating, 400x600x38mm                    | PNC 922189 | <input type="checkbox"/> |
| • Baking tray with 4 edges in perforated aluminum, 400x600x20mm  | PNC 922190 | <input type="checkbox"/> |
| • Baking tray with 4 edges in aluminum, 400x600x20mm   | PNC 922191 | <input type="checkbox"/> |
| • Pair of frying baskets   | PNC 922239 | <input type="checkbox"/> |
| • AISI 304 stainless steel bakery/pastry grid 400x600mm  | PNC 922264 | <input type="checkbox"/> |
| • Double-step door opening kit   | PNC 922265 | <input type="checkbox"/> |
| • Grid for whole chicken (8 per grid - 1,2kg each), GN 1/1   | PNC 922266 | <input type="checkbox"/> |
| • USB probe for sous-vide cooking  | PNC 922281 | <input type="checkbox"/> |
| • Grease collection tray, GN 1/1, H=100 mm   | PNC 922321 | <input type="checkbox"/> |
| • Kit universal skewer rack and 4 long skewers for Lengthwise ovens  | PNC 922324 | <input type="checkbox"/> |
| • Universal skewer rack  | PNC 922326 | <input type="checkbox"/> |

SkyLine PremiumS  
Electric Combi Oven 6GN 1/1, left hinged door

The company reserves the right to make modifications to the products without prior notice. All information correct at time of printing.

2025.01.21

• 4 long skewers	PNC 922327	<input type="checkbox"/>	• Grease collection kit for GN 1/1-2/1 open base (2 tanks, open/close device for drain)	PNC 922639	<input type="checkbox"/>
• Volcano Smoker for lengthwise and crosswise oven	PNC 922338	<input type="checkbox"/>	• Wall support for 6 GN 1/1 oven	PNC 922643	<input type="checkbox"/>
• Multipurpose hook	PNC 922348	<input type="checkbox"/>	• Dehydration tray, GN 1/1, H=20mm	PNC 922651	<input type="checkbox"/>
• 4 flanged feet for 6 & 10 GN , 2", 100-130mm	PNC 922351	<input type="checkbox"/>	• Flat dehydration tray, GN 1/1	PNC 922652	<input type="checkbox"/>
• Grid for whole duck (8 per grid - 1,8kg each), GN 1/1	PNC 922362	<input type="checkbox"/>	• Open base for 6 & 10 GN 1/1 oven, disassembled - NO accessory can be fitted with the exception of 922382	PNC 922653	<input type="checkbox"/>
• Tray support for 6 & 10 GN 1/1 disassembled open base	PNC 922382	<input type="checkbox"/>	• Bakery/pastry rack kit for 6 GN 1/1 oven with 5 racks 400x600mm and 80mm pitch	PNC 922655	<input type="checkbox"/>
• Wall mounted detergent tank holder	PNC 922386	<input type="checkbox"/>	• Stacking kit for 6 GN 1/1 combi oven on 15&25kg blast chiller/freezer crosswise	PNC 922657	<input type="checkbox"/>
• USB single point probe	PNC 922390	<input type="checkbox"/>	• Heat shield for stacked ovens 6 GN 1/1 on 6 GN 1/1	PNC 922660	<input type="checkbox"/>
• IoT module for OnE Connected and SkyDuo (one IoT board per appliance - to connect oven to blast chiller for Cook&Chill process).	PNC 922421	<input type="checkbox"/>	• Heat shield for stacked ovens 6 GN 1/1 on 10 GN 1/1	PNC 922661	<input type="checkbox"/>
• Connectivity router (WiFi and LAN)	PNC 922435	<input type="checkbox"/>	• Heat shield for 6 GN 1/1 oven	PNC 922662	<input type="checkbox"/>
• Grease collection kit for ovens GN 1/1 & 2/1 (2 plastic tanks, connection valve with pipe for drain)	PNC 922438	<input type="checkbox"/>	• Compatibility kit for installation of 6 GN 1/1 electric oven on previous 6 GN 1/1 electric oven (old stacking kit 922319 is also needed)	PNC 922679	<input type="checkbox"/>
• SkyDuo Kit - to connect oven and blast chiller freezer for Cook&Chill process. The kit includes 2 boards and cables. Not for OnE Connected	PNC 922439	<input type="checkbox"/>	• Fixed tray rack for 6 GN 1/1 and 400x600mm grids	PNC 922684	<input type="checkbox"/>
• Tray rack with wheels, 6 GN 1/1, 65mm pitch	PNC 922600	<input type="checkbox"/>	• Kit to fix oven to the wall	PNC 922687	<input type="checkbox"/>
• Tray rack with wheels, 5 GN 1/1, 80mm pitch	PNC 922606	<input type="checkbox"/>	• Tray support for 6 & 10 GN 1/1 oven base	PNC 922690	<input type="checkbox"/>
• Bakery/pastry tray rack with wheels 400x600mm for 6 GN 1/1 oven and blast chiller freezer, 80mm pitch (5 runners)	PNC 922607	<input type="checkbox"/>	• 4 adjustable feet with black cover for 6 & 10 GN ovens, 100-115mm	PNC 922693	<input type="checkbox"/>
• Slide-in rack with handle for 6 & 10 GN 1/1 oven	PNC 922610	<input type="checkbox"/>	• Detergent tank holder for open base	PNC 922699	<input type="checkbox"/>
• Open base with tray support for 6 & 10 GN 1/1 oven	PNC 922612	<input type="checkbox"/>	• Bakery/pastry runners 400x600mm for 6 & 10 GN 1/1 oven base	PNC 922702	<input type="checkbox"/>
• Cupboard base with tray support for 6 & 10 GN 1/1 oven	PNC 922614	<input type="checkbox"/>	• Wheels for stacked ovens	PNC 922704	<input type="checkbox"/>
• Hot cupboard base with tray support for 6 & 10 GN 1/1 oven holding GN 1/1 or 400x600mm trays	PNC 922615	<input type="checkbox"/>	• Mesh grilling grid, GN 1/1	PNC 922713	<input type="checkbox"/>
• External connection kit for liquid detergent and rinse aid	PNC 922618	<input type="checkbox"/>	• Probe holder for liquids	PNC 922714	<input type="checkbox"/>
• Grease collection kit for GN 1/1-2/1 cupboard base (trolley with 2 tanks, open/close device for drain)	PNC 922619	<input type="checkbox"/>	• Odour reduction hood with fan for 6 & 10 GN 1/1 electric ovens	PNC 922718	<input type="checkbox"/>
• Stacking kit for 6+6 GN 1/1 ovens on electric 6+10 GN 1/1 GN ovens	PNC 922620	<input type="checkbox"/>	• Odour reduction hood with fan for 6+6 or 6+10 GN 1/1 electric ovens	PNC 922722	<input type="checkbox"/>
• Trolley for slide-in rack for 6 & 10 GN 1/1 oven and blast chiller freezer	PNC 922626	<input type="checkbox"/>	• Condensation hood with fan for 6 & 10 GN 1/1 electric oven	PNC 922723	<input type="checkbox"/>
• Trolley for mobile rack for 2 stacked 6 GN 1/1 ovens on riser	PNC 922628	<input type="checkbox"/>	• Condensation hood with fan for stacking 6+6 or 6+10 GN 1/1 electric ovens	PNC 922727	<input type="checkbox"/>
• Trolley for mobile rack for 6 GN 1/1 on 6 or 10 GN 1/1 ovens	PNC 922630	<input type="checkbox"/>	• Exhaust hood with fan for 6 & 10 GN 1/1 ovens	PNC 922728	<input type="checkbox"/>
• Riser on feet for 2 6 GN 1/1 ovens or a 6 GN 1/1 oven on base	PNC 922632	<input type="checkbox"/>	• Exhaust hood with fan for stacking 6+6 or 6+10 GN 1/1 ovens	PNC 922732	<input type="checkbox"/>
• Riser on wheels for stacked 2x6 GN 1/1 ovens, height 250mm	PNC 922635	<input type="checkbox"/>	• Exhaust hood without fan for 6&10 1/1GN ovens	PNC 922733	<input type="checkbox"/>
• Stainless steel drain kit for 6 & 10 GN oven, dia=50mm	PNC 922636	<input type="checkbox"/>	• Exhaust hood without fan for stacking 6+6 or 6+10 GN 1/1 ovens	PNC 922737	<input type="checkbox"/>
• Plastic drain kit for 6 & 10 GN oven, dia=50mm	PNC 922637	<input type="checkbox"/>	• Fixed tray rack, 5 GN 1/1, 85mm pitch	PNC 922740	<input type="checkbox"/>
• Trolley with 2 tanks for grease collection	PNC 922638	<input type="checkbox"/>	• 4 high adjustable feet for 6 & 10 GN ovens, 230-290mm	PNC 922745	<input type="checkbox"/>
			• Tray for traditional static cooking, H=100mm	PNC 922746	<input type="checkbox"/>
			• Double-face griddle, one side ribbed and one side smooth, 400x600mm	PNC 922747	<input type="checkbox"/>
			• Trolley for grease collection kit	PNC 922752	<input type="checkbox"/>
			• Water inlet pressure reducer	PNC 922773	<input type="checkbox"/>



- Kit for installation of electric power peak management system for 6 & 10 GN Oven PNC 922774
- Extension for condensation tube, 37cm PNC 922776
- Non-stick universal pan, GN 1/1, H=20mm PNC 925000
- Non-stick universal pan, GN 1/1, H=40mm PNC 925001
- Non-stick universal pan, GN 1/1, H=60mm PNC 925002
- Double-face griddle, one side ribbed and one side smooth, GN 1/1 PNC 925003
- Aluminum grill, GN 1/1 PNC 925004
- Frying pan for 8 eggs, pancakes, hamburgers, GN 1/1 PNC 925005
- Flat baking tray with 2 edges, GN 1/1 PNC 925006
- Baking tray for 4 baguettes, GN 1/1 PNC 925007
- Potato baker for 28 potatoes, GN 1/1 PNC 925008
- Non-stick universal pan, GN 1/2, H=20mm PNC 925009
- Non-stick universal pan, GN 1/2, H=40mm PNC 925010
- Non-stick universal pan, GN 1/2, H=60mm PNC 925011
- Compatibility kit for installation on previous base GN 1/1 PNC 930217

**Recommended Detergents**

- C25 Rinse & Descale Tabs, 50 tabs bucket PNC 0S2394
- C22 Cleaning Tabs, phosphate-free, 100 bags bucket PNC 0S2395



Front

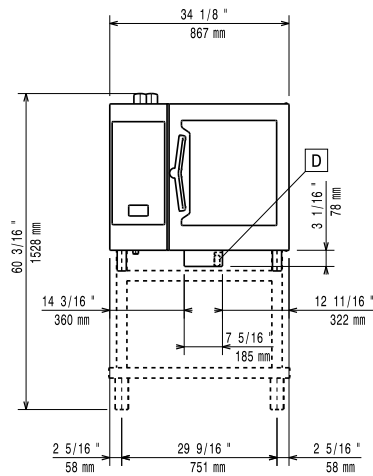

Side

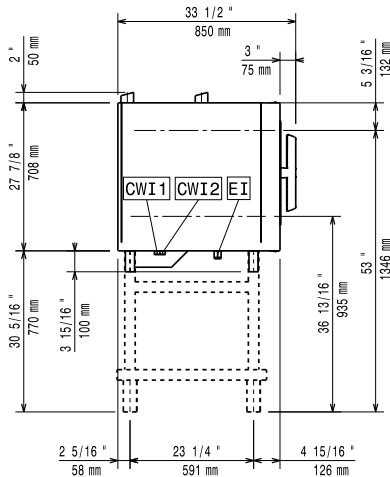

- CWI1 = Cold Water inlet 1 (cleaning)      EI = Electrical inlet (power)  
 CWI2 = Cold Water Inlet 2 (steam generator)  
 D = Drain  
 DO = Overflow drain pipe

Top

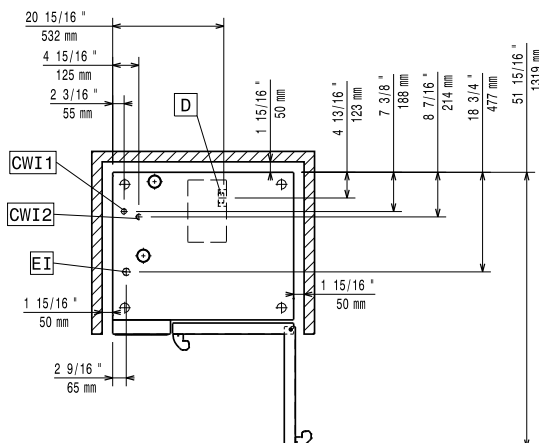

### Electric

#### Supply voltage:

217726 (ECO6IT2AL) 380-415 V/3N ph/50-60 Hz

#### Electrical power, default:

11.1 kW

Default power corresponds to factory test conditions.

When supply voltage is declared as a range the test is performed at the average value. According to the country, the installed power may vary within the range.

#### Electrical power max.:

11.8 kW

#### Circuit breaker required

### Water:

#### Water inlet connections "CWI1-CWI2":

3/4"

#### Pressure, bar min/max:

1-6 bar

#### Drain "D":

50mm

#### Max inlet water supply temperature:

30 °C

#### Chlorides:

<45 ppm

#### Conductivity:

>50 µS/cm

Electrolux Professional recommends the use of treated water, based on testing of specific water conditions.

Please refer to user manual for detailed water quality information.

### Installation:

#### Clearance:

Clearance: 5 cm rear and right hand sides.

#### Suggested clearance for service access:

50 cm left hand side.

### Capacity:

#### Trays type:

6 - 1/1 Gastronorm

#### Max load capacity:

30 kg

### Key Information:

#### Door hinges:

External dimensions, Width: 867 mm

External dimensions, Depth: 775 mm

External dimensions, Height: 808 mm

#### Net weight:

117 kg

#### Shipping weight:

134 kg

#### Shipping volume:

0.89 m<sup>3</sup>

### ISO Certificates

#### ISO Standards:

ISO 9001; ISO 14001; ISO 45001; ISO 50001